



Optimization of medium piston in the grinding process of inside surfaces

The new modular medium piston of MICRO SURFACES will minimize the exchange of spare parts in the future.

In case of wear of the sealing edge, the exchange of only the piston seal and - after an extended runtime - the guide band is required.

You can benefit from the advantages of:

- + Procurement of wear parts 300% cheaper in the future
- + Shorter delivery terms from 6 weeks to 2 weeks
- + Eco-friendly due to reduced costs of materials
- + More assembly-friendly due to reduced piston weight

Task of the medium piston:

The medium piston has the task to press the grinding paste in the medium container through the work-piece to be processed. For this purpose, it must be located sufficiently nearby the medium container wall in order to avoid the occurrence of grinding paste behind the medium piston. The grinding paste contains abrasive particles, leading to the wear of the sealing edge of the medium piston.

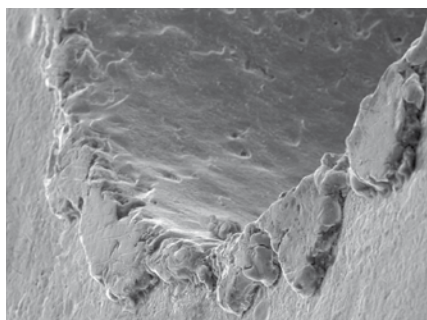

Bore beforehand

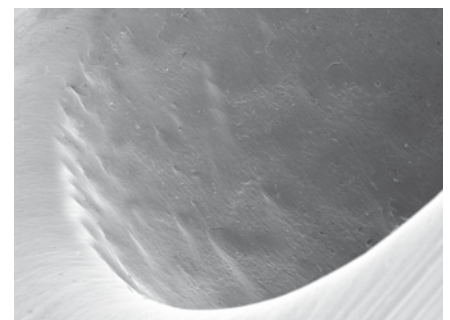

Bore afterwards

Switching to NEW is possible at any time!

OLD

Medium pistons used so far.

They must be exchanged completely in case of wear.

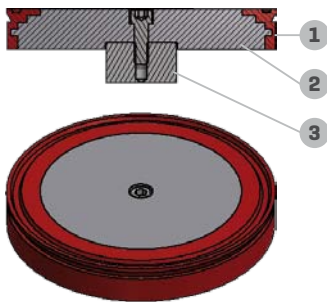

Weight: approx. 6 kg

- 1: PU coating, sprayed on
- 2: Steel core
- 3: Piston rod

NEW

New, modular medium piston:

In case of wear of the sealing edge, only the exchange of the piston seal and – after an extended runtime – the guide band is required.

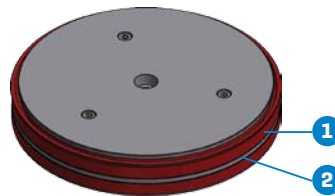

Weight saving up to 50%

- 1: Piston seal
- 2: Guide band



Contact

Sales:

Phone: +49 7141 91167-24
 Fax: +49 7141 91167-29

Micro Surfaces GmbH

Kleines Wegle 5
 71691 Freiberg am Neckar
 GERMANY
 Phone: +49 7141 91167-0
 Fax: +49 7141 91167-29
 info@microsurfaces.de
 www.microsurfaces.de

MICRO SURFACES offers everything from one single source ...

... we develop, design, manufacture and sell state-of-the-art processes for the deburring and surface technology and precision processing systems.

We look forward to your request!